

REVISIONS				
DRWN	DATE	CHK'D	REV	DESCRIPTION
CR	7SEP16		A	PRELIMINARY RELEASE

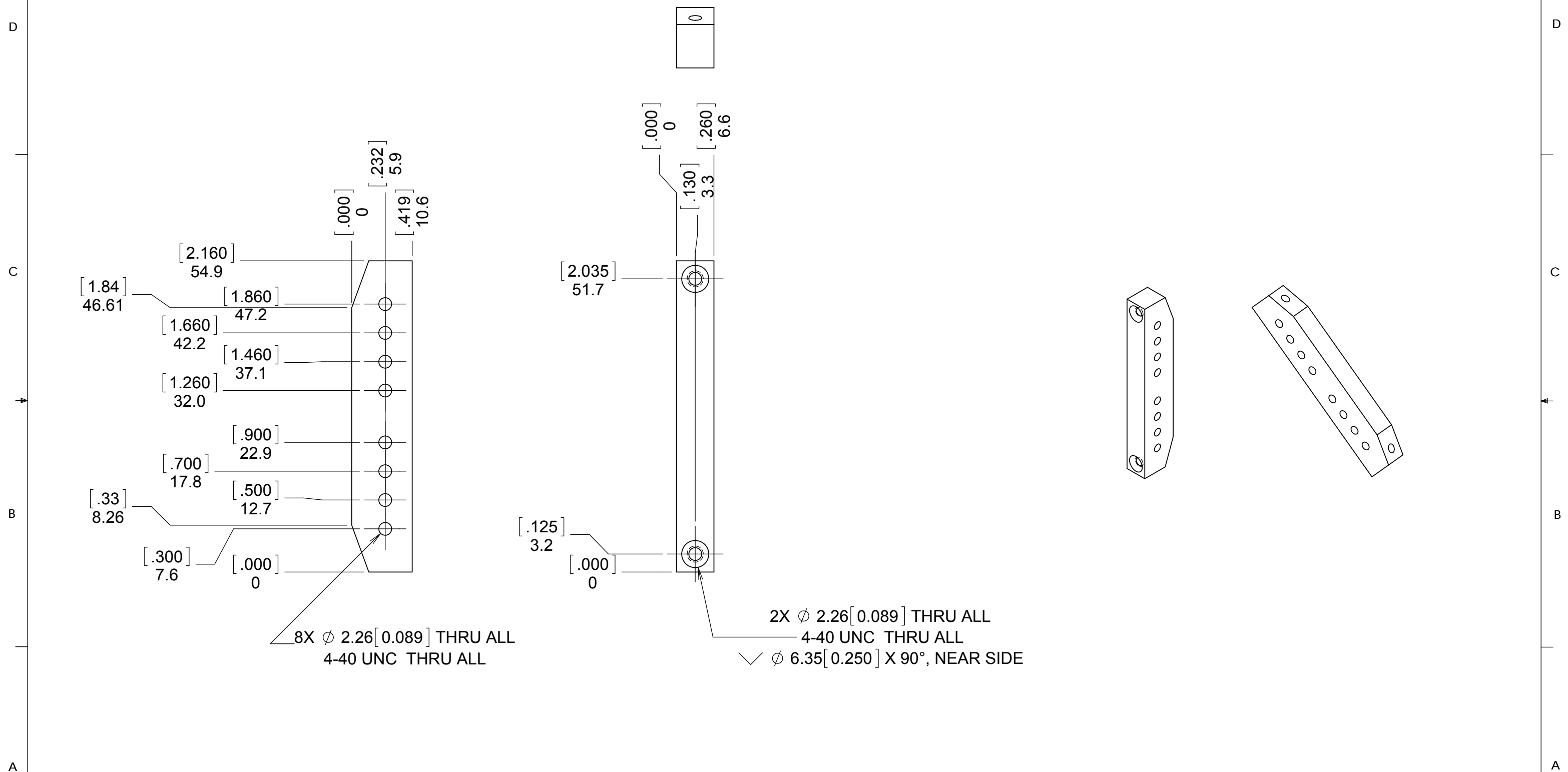

NOTES:
1. MATERIAL: DELRIN

UNLESS OTHERWISE NOTED DIMENSIONS ARE IN MILLIMETERS & TOLERANCES ARE AS FOLLOWS:
X.X: ± 0.10 mm X.XX: ± 0.01 mm
ANGLES: $\pm 0.5^\circ$ FINISH: 3 MICRONS (μ m)
BREAK ALL SHARP EDGES & CORNERS .25mm MAX

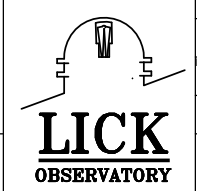

DRAWN C. RATLIFF		KECK 1 DEPLOYABLE TERTIARY MIRROR	
CHECKED J. WARD		ROTARY SUPPORT STRUCTURE	
DESIGNED JW&CR	9/7/16	TITLE INNER DRUM LOW VOLTAGE SEPARATORS	
ENGINEER C. RATLIFF	9/7/16	QUANTITY 30	PROJECT CODE K1D3FD
MATERIAL SEE NOTE 1	FINISH --	872-LM2212.SLDPRT	DWG NO 872-LM2212
		NEXT ASSY KDM2000	REV A