

REVISIONS				
DRWN	DATE	CHK'D	REV	DESCRIPTION
CR	11/3/2016		A	PRELIMINARY RELEASE

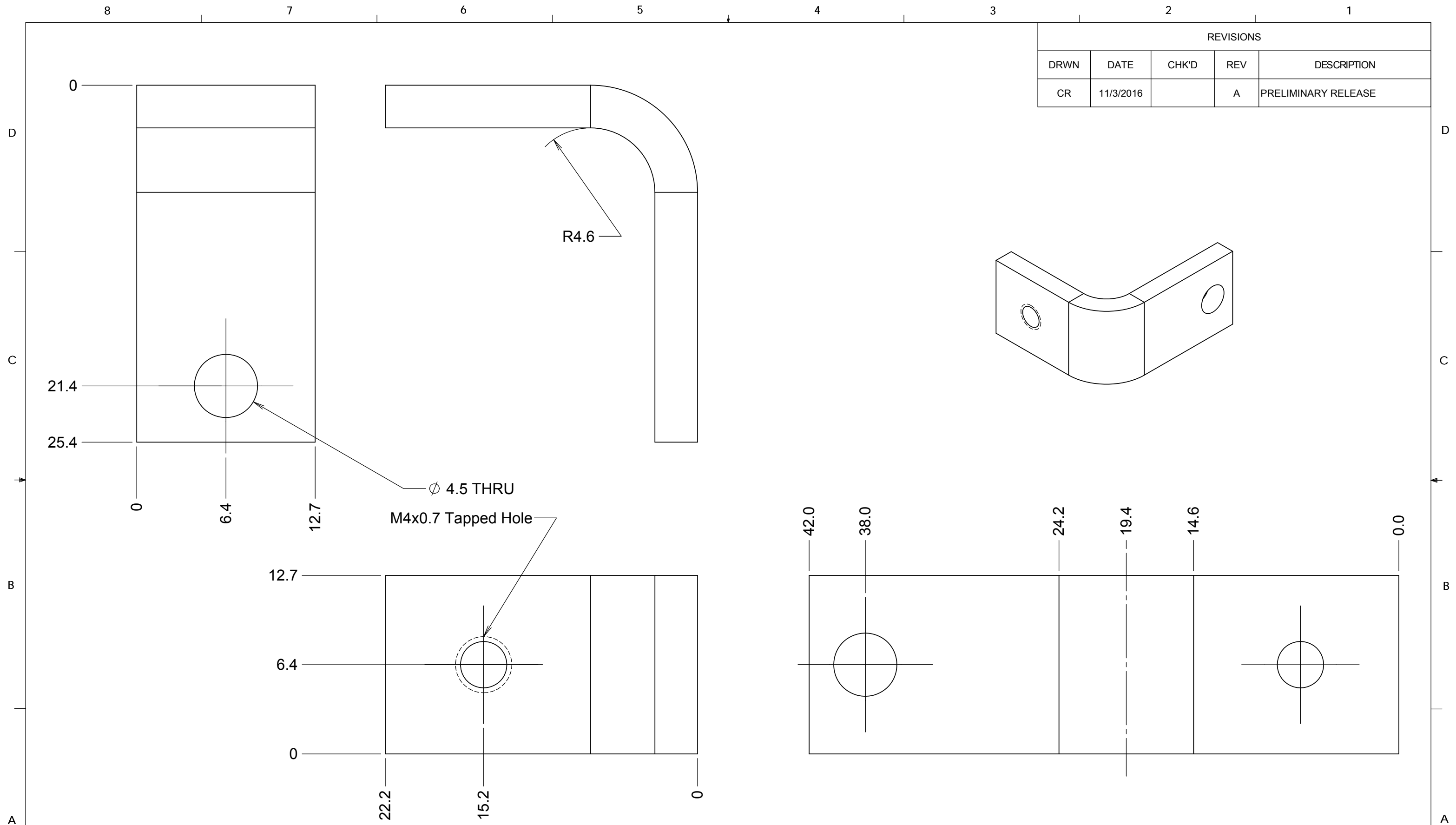

- NOTES**
- MATERIAL: 11 GA. STEEL SHEET METAL (0.1196in)
 - MAXIMUM BEND RADIUS: 4.6MM
 - TAPPED HOLE ALLOWS FOR OUTER DRUM CLEARANCE
 - ALL POSITION TOLERANCE ARE +/- 0.25MM, HOLES SIZE TOLERANCE PER TITLE BLOCK

UNLESS OTHERWISE NOTED DIMENSIONS ARE IN MILLIMETERS & TOLERANCES ARE AS FOLLOWS: X.X: ±0.10 mm X.XX: ±0.01 mm ANGLES: ±0.5° FINISH: 3 MICRONS (µm) BREAK ALL SHARP EDGES & CORNERS .25mm MAX			DRAWN C. RATLIFF	KECK 1 DEPLOYABLE TERTIARY MIRROR	
SEE NOTE 1			CHECKED J. WARD	INNER DRUM	
			DESIGNED C. RATLIFF	11/3/16	TITLE GALIL MOUNT TAB
			ENGINEER C. RATLIFF	11/3/16	PROJECT CODE K1D3FD
			SW DOCUMENT FILE 872-LM2235.SLDPRJT	QUANTITY 4	DWG NO 872-LM2000
					REV A
					872-LM2235