

REVISIONS				
REV	DATE	DRWN	CHK'D	DESCRIPTION
A	2/27/2017	CR		INITIAL RELEASE

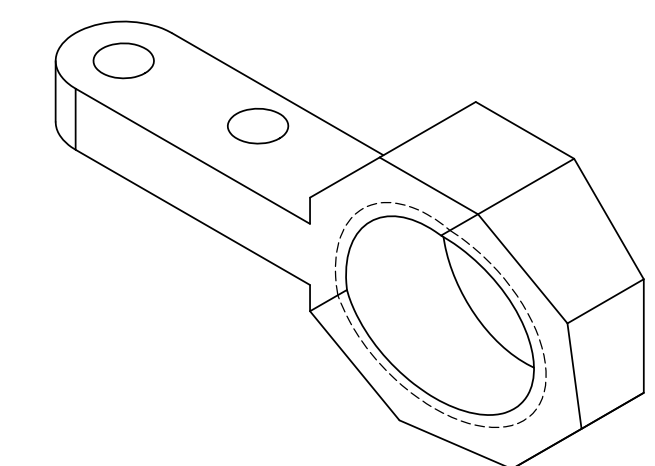
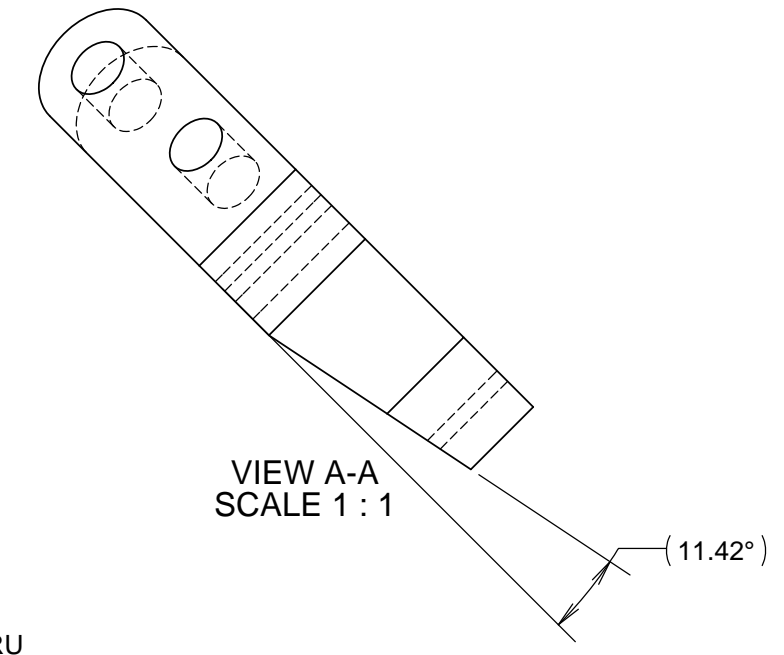
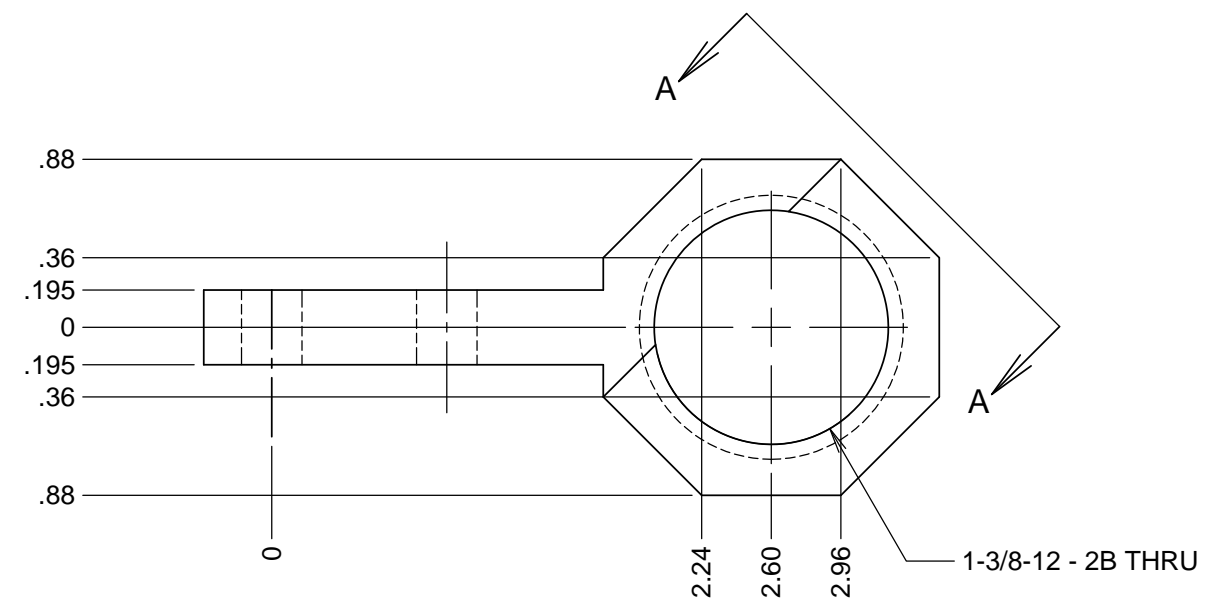
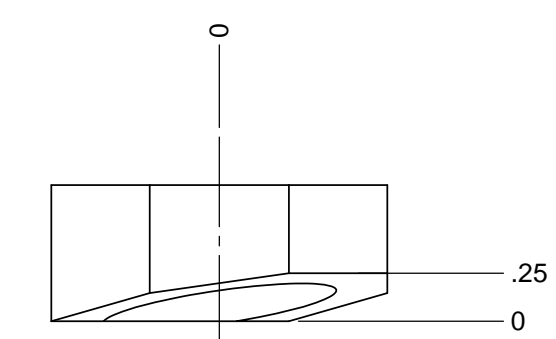
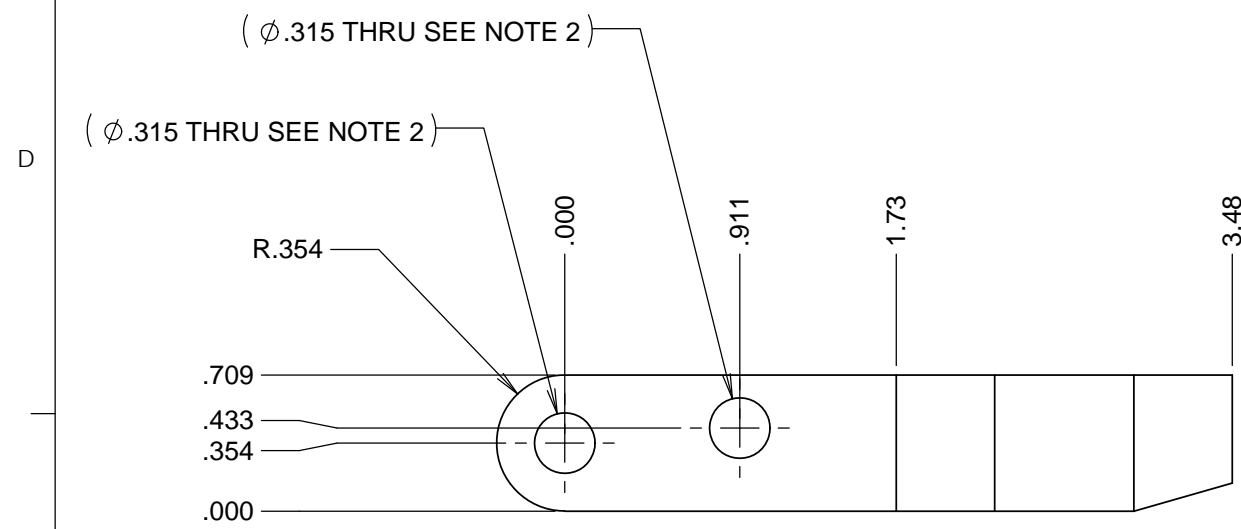

- NOTES**
- MATERIAL: 300 SERIES STAINLESS STEEL OR 17-4PH OR CHROMIUM NITRIDE COATED 4130 STEEL OR SIMILAR
 - HOLE DIAMETERS HERE SHOULD MATCH THAT OF THE STOCK PART, NEEDS TO BE MEASURED, HOLE LOCATIONS SHOULD ALSO MATCH THE STOCK PART

UNLESS OTHERWISE NOTED DIMENSIONS ARE IN INCHES & TOLERANCES ARE AS FOLLOWS X.X: ±0.1000" X.XX: ±0.0100" X.XXX: ±0.0050" X.XXXX: ±0.0001" ANGLES: ±0.5° FINISH: 125 MICRO INCHES BREAK ALL SHARP EDGES & CORNERS .002" MAX			DRAWN RATLIFF	--	PROJECT CODE	872-LM2250	DWG NO 872-LM2250 RE A 1/1
MATERIAL SEE NOTE 1	FINISH NA		CHECKED J. WARD	2/27/2017	TITLE DIE SPRING HINGE CLAMP SWING ARM B	QUANTITY 1	
			DESIGNED --	--	NEXT ASSY 872-LM2250		
			ENGINEER --	--			
			SW DOCUMENT FILE				