

REVISIONS				
DRWN	DATE	CHK'D	REV	DESCRIPTION
CR	10OCT17		A	PRELIMINARY RELEASE

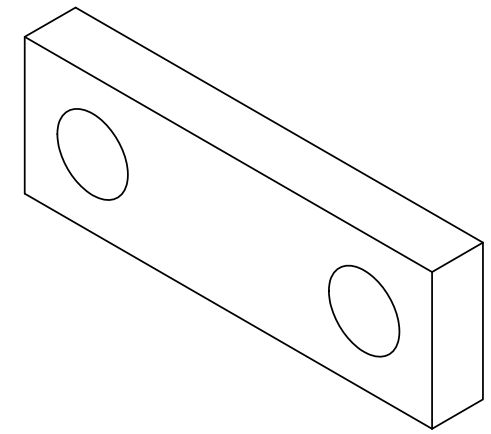
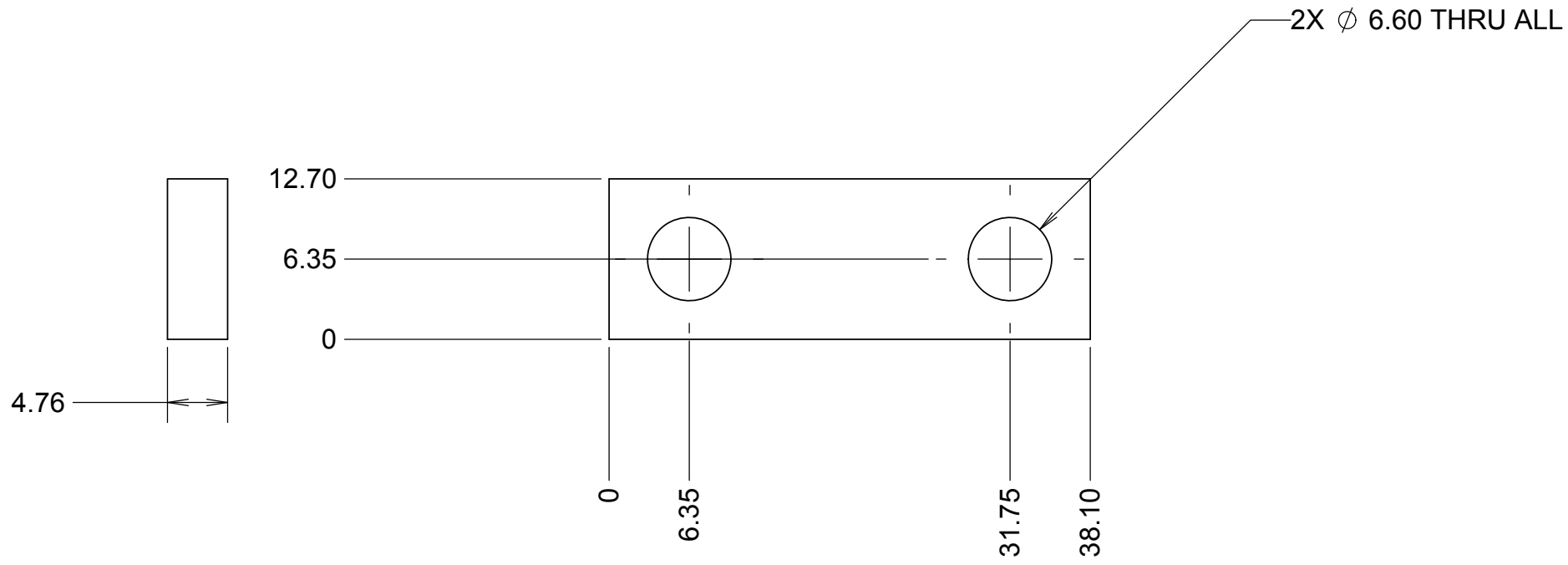

**NOTES**

- 1 CAD MODEL FILENAME, 872-LM2263 GUIDE WASHER PLATE
- 2 MATERIAL: BLACK DELRIN
- 3. BREAK ALL SHARP EDGES

UNLESS OTHERWISE NOTED DIMENSIONS ARE IN MILLIMETERS & TOLERANCES ARE AS FOLLOWS:  
 X.X: ±0.10 mm X.XX: ±0.05 mm  
 ANGLES: ±0.5° FINISH: 3 MICRONS (µm)  
 BREAK ALL SHARP EDGES & CORNERS .25mm MAX

MATERIAL	FINISH
SEE NOTES	

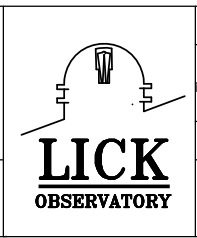

DRAWN <b>C. RATLIFF</b>		KECK 1 DEPLOYABLE TERTIARY MIRROR	
CHECKED <b>DM</b>	TBD	INNER DRUM	
DESIGNED <b>C. RATLIFF</b>	NA	GUIDE WASHER PLATE	
ENGINEER		PROJECT CODE <b>K1D3FD</b>	DWG NO <b>872-LM0000</b>
SW DOCUMENT FILE 872-LM2263 GUIDE WASHER PLATE	QUANTITY <b>1</b>	REV <b>A</b>	
		<b>872-LM2263</b>	