

REVISIONS				
DRWN	DATE	CHK'D	REV	DESCRIPTION
CR	2NOV17		A	PRELIMINARY RELEASE

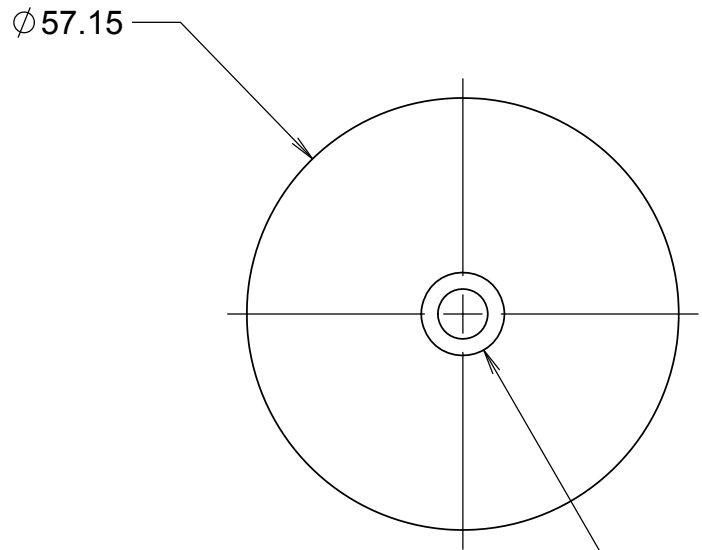

Ø 6.6 THRU ALL
 □ Ø 11.0 ▽ 6.0
 CBORE FOR M6 SHCS

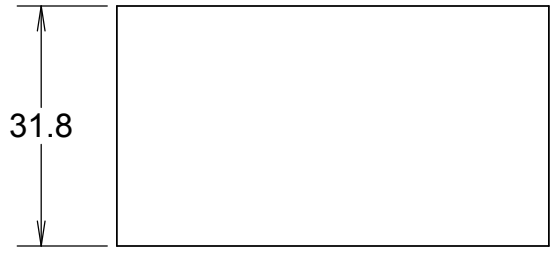
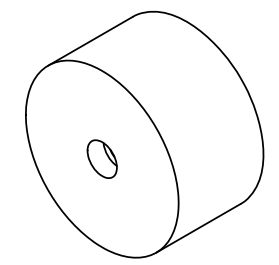

- NOTES**
- CAD MODEL FILENAME, 872-LM2268 Counterweight F
 - MATERIAL: BRASS
 - BREAK ALL SHARP EDGES
 - PAINT BLACK WITH BEST KNOWN METHODS

UNLESS OTHERWISE NOTED DIMENSIONS ARE IN MILLIMETERS & TOLERANCES ARE AS FOLLOWS:
 X.X: ±0.10 mm X.XX: ±0.05 mm
 ANGLES: ±0.5° FINISH: 3 MICRONS (µm)
 BREAK ALL SHARP EDGES & CORNERS .25mm MAX

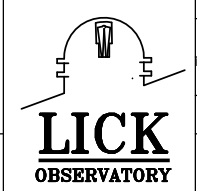

MATERIAL	FINISH		DRAWN C. RATLIFF CHECKED DM	TBD	PROJECT CODE K1D3FD		DWG NO	872-LM2268	REV
SEE NOTES			DESIGNED C. RATLIFF ENGINEER	NA	TITLE	NEXT ASSY 872-LM0000	1		A

KECK 1 DEPLOYABLE TERTIARY MIRROR INNER DRUM		
COUNTERWEIGHT F		