

REVISIONS				
REV	DATE	DRWN	CHK'D	DESCRIPTION
A	13AUG15	CR		PRE- RELEASE
B	13DEC16	GFC	CR	DESIGN UPDATE
C	14DEC16	GFC	CR	NEW DOC NUMBER, ACTUATOR UPDATED
D	10JAN17	GFC		PART CHANGE
E	28APR17	GFC	JW	ADDED HOLES TO BRACKET
F	30MAY17	GFC	JW	HOLE CHANGE

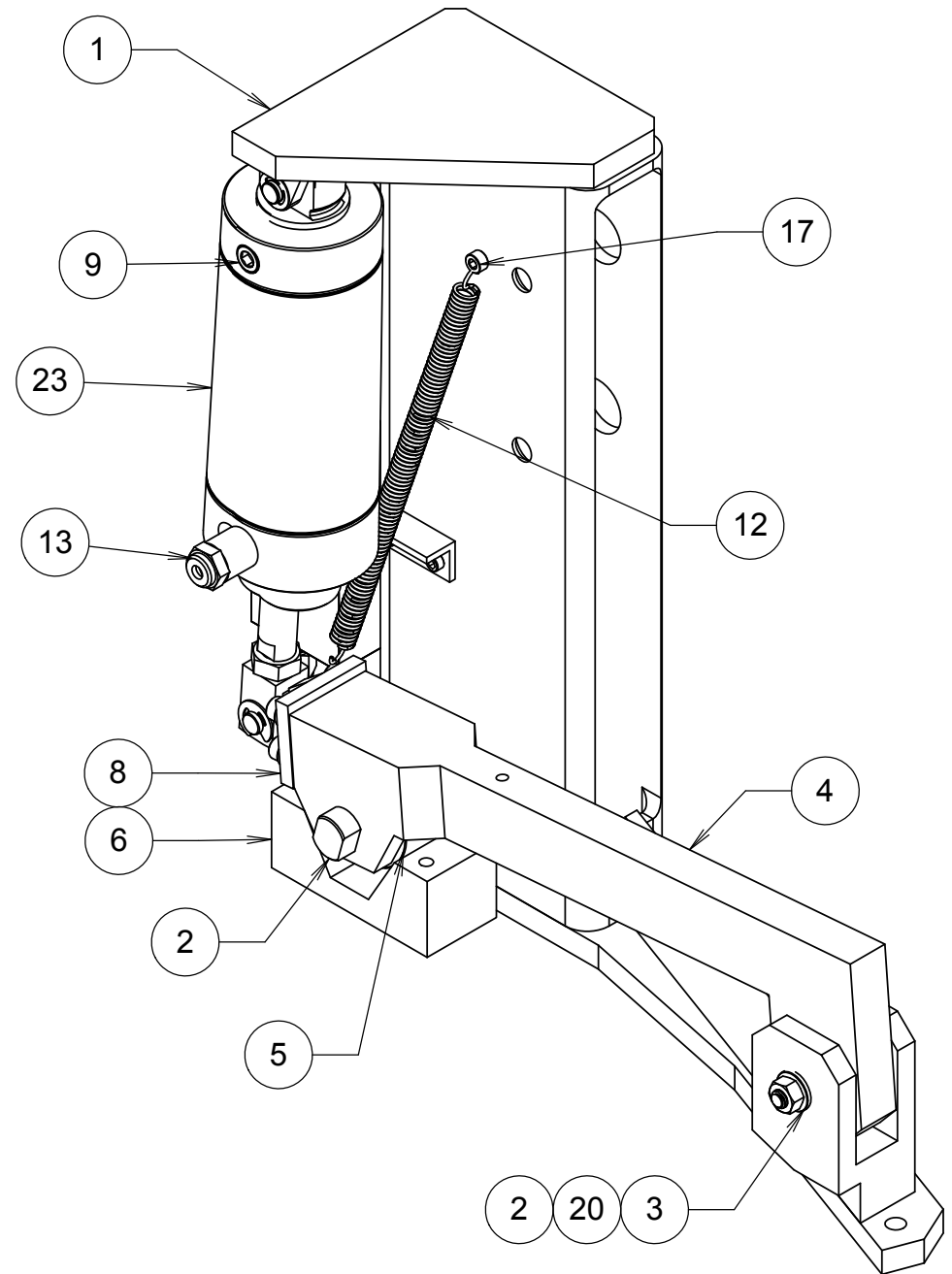

ITEM	QTY	PartNo	DESCRIPTION
1	1	199-06-07-30	POSITIONER BRACKET, KECK
2	2	199-06-07-33	PIVOT PIN, KECK
3	2	199-06-07-35	BUSHING, KECK
4	1	199-06-07-36	LEVER, KECK
5	1	199-06-07-37	ROLLER, KECK
6	1	199-06-07-38	VEE BLOCK, KECK
7	1	872-LM3138	BRACKET, SOLENOID VALVE, DRUM POSITIONER
8	1	872-LM3165	NEW PIVOT BRACKET
9	1	4452K542	PLUG, 1/4" NPT, HEX DRIVE, MMC
10	1	5182K142	TUBE FITTING, 1/4" X MALE 1/4" NPT, 90 DEG, YOR-LOK, MMC
11	1	5182K821	TUBE FITTING, YOR-LOK, 1/4 X MALE 1/8" NPT, 90, MMC
12	1	5596	EXTENSION SPRING, CENTURY SPRING
13	1	9164K120	QUICK-EXHAUST AIR VALVE, FLOW CONTROL, MMC
14	2	90792A336	SHIM, 3/8" ID X .010" THK, MCMaster-CARR
15	4	A2037-A2126	TS BEARING ASSEMBLY, TIMKEN
16	1	CAT44P-00N	SOLENOID CONTROL VALVE, INGERSOLL RAND
17	1	HW	SHCS, M5X10
18	4	HW	SHCS, M6X12
19	4	HW	WASHER, FLAT, M6
20	2	HW	HEX NUT, M8
21	4	HW	SHCS, BLACK OXIDE, 8-32 X 1/2
22	1	M-503-DXP	PNEUMATIC ACTUATOR, BIMBA
23	1	M-503-DXP(SP)	PNEUMATIC ACTUATOR/ROD ASSY, BIMBA
24	1	TUBING	FLEXIBLE TUBING, 1/4" OD X .035 WALL

NOTES

[I] CAD MODEL SOURCE FILE, 872-LM3109 Inner Drum Positioner

UNLESS OTHERWISE NOTED DIMENSIONS ARE IN MILLIMETERS & TOLERANCES ARE AS FOLLOWS: X: ±0.25mm XX: ±0.10mm XXX: ±0.01mm ANGLES: ±0.5° FINISH: 3 MICRONS (µm) BREAK ALL SHARP EDGES & CORNERS .25mm MAX			DRAWN: RATLIFF CHECKED: DESIGNED: ENGINEER:	DATE: 8/13/15 TITLE: AUG2015 PROJECT CODE: K1D3DD DWG NO: 872-LM3109	KECK DEPLOYABLE TERTIARY MIRROR OUTER DRUM ASSEMBLY INNER DRUM POSITIONER
PARTS LIST	FINISH: --		SW DOCUMENT FILE: <input type="checkbox"/> QUANTITY: -- NEXT ASSY: --	REV: F 1/3	

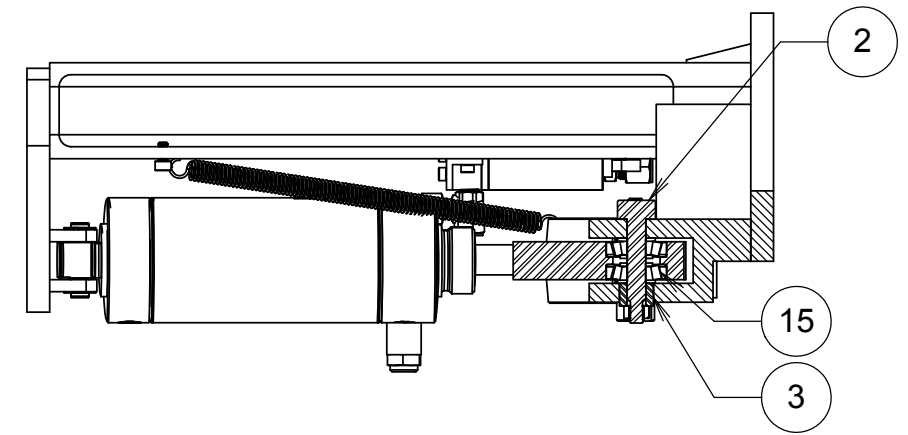
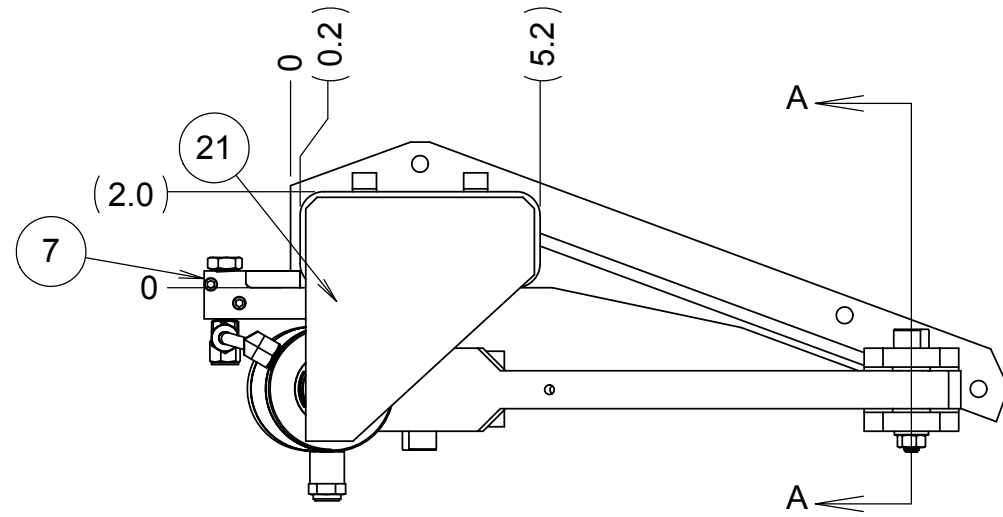

SECTION A-A
SCALE 1 : 4

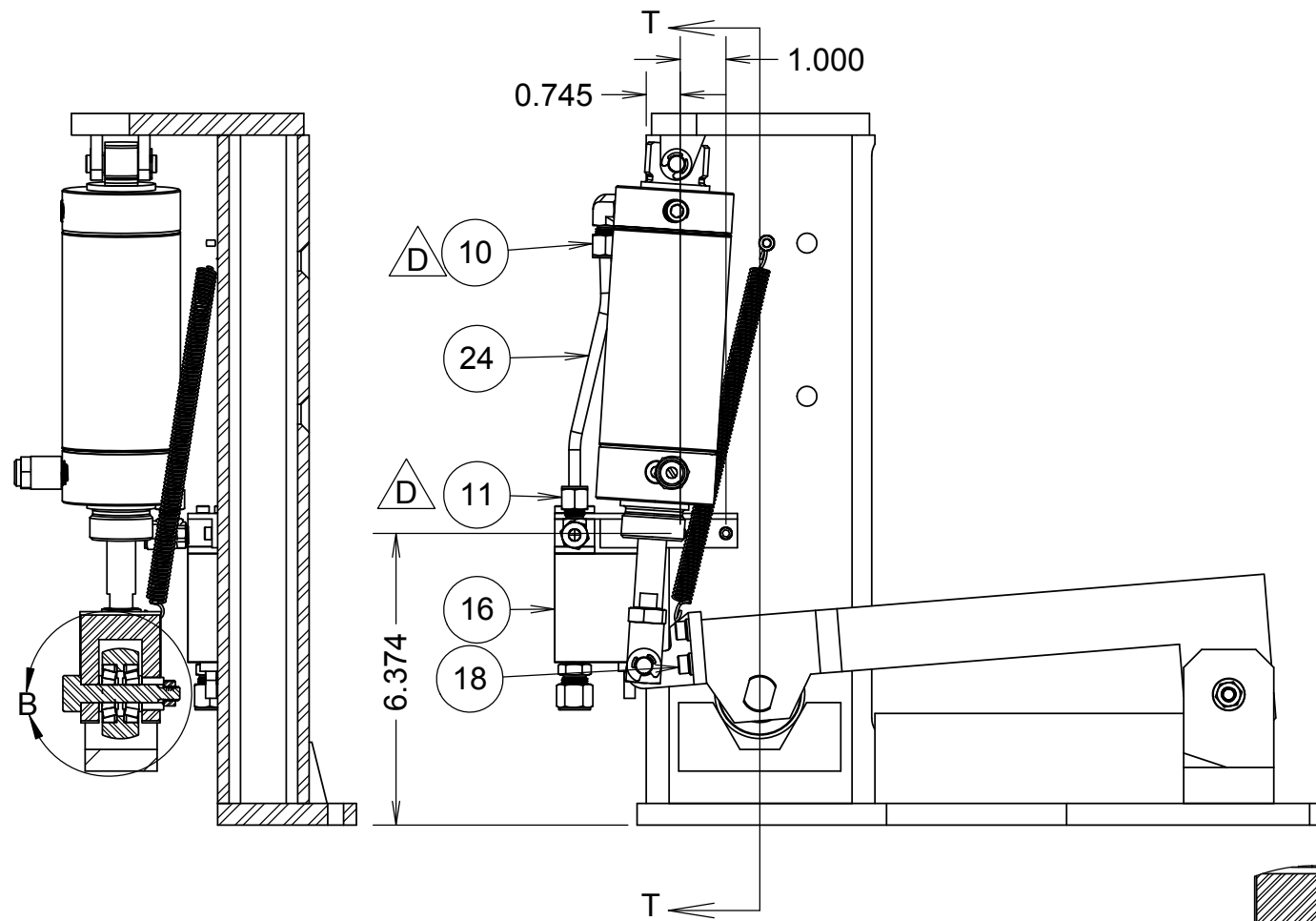

SECTION T-T
SCALE 1 : 4

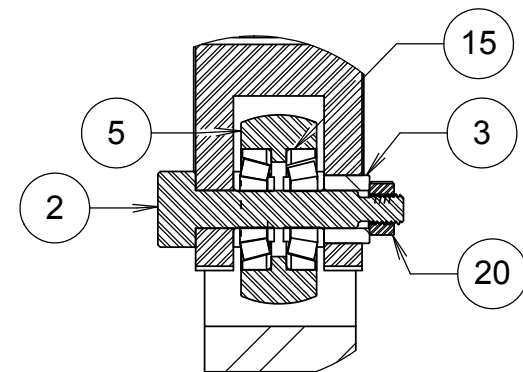

DETAIL B
SCALE 1 : 2

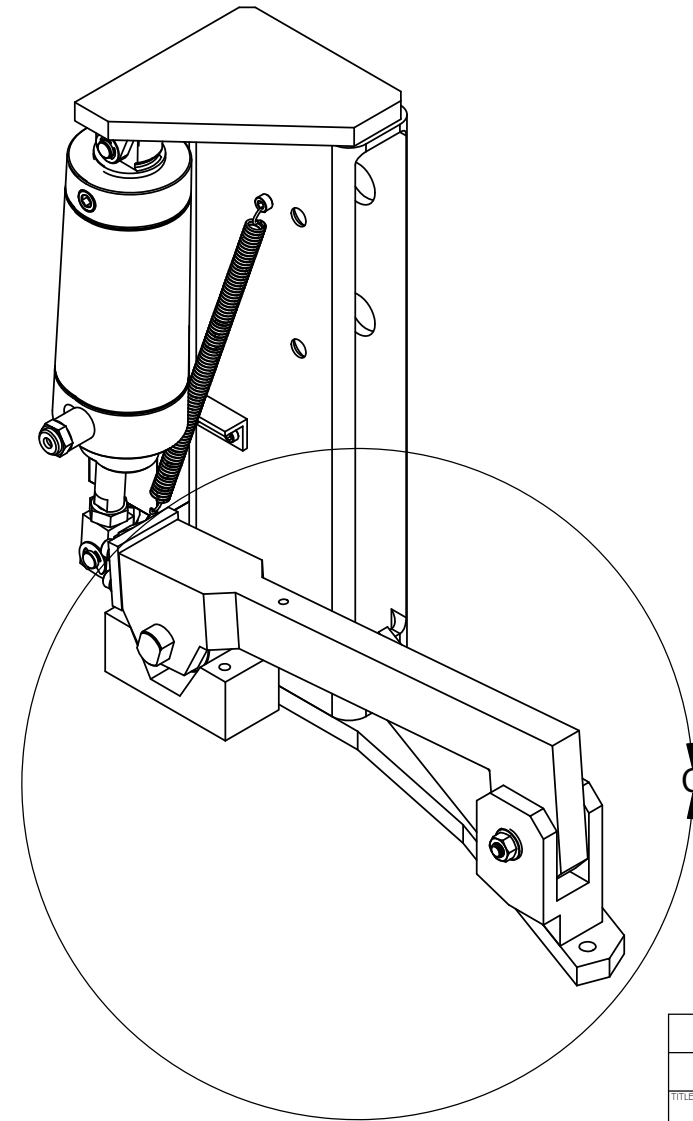

KECK I DEPLOYABLE TERTIARY MIRROR	
OUTER DRUM ASSEMBLY	
TITLE INNER DRUM POSITIONER	
PROJECT CODE K1D3DD	DWG NO 872-LM3109
NEXT ASSY --	F 2/3

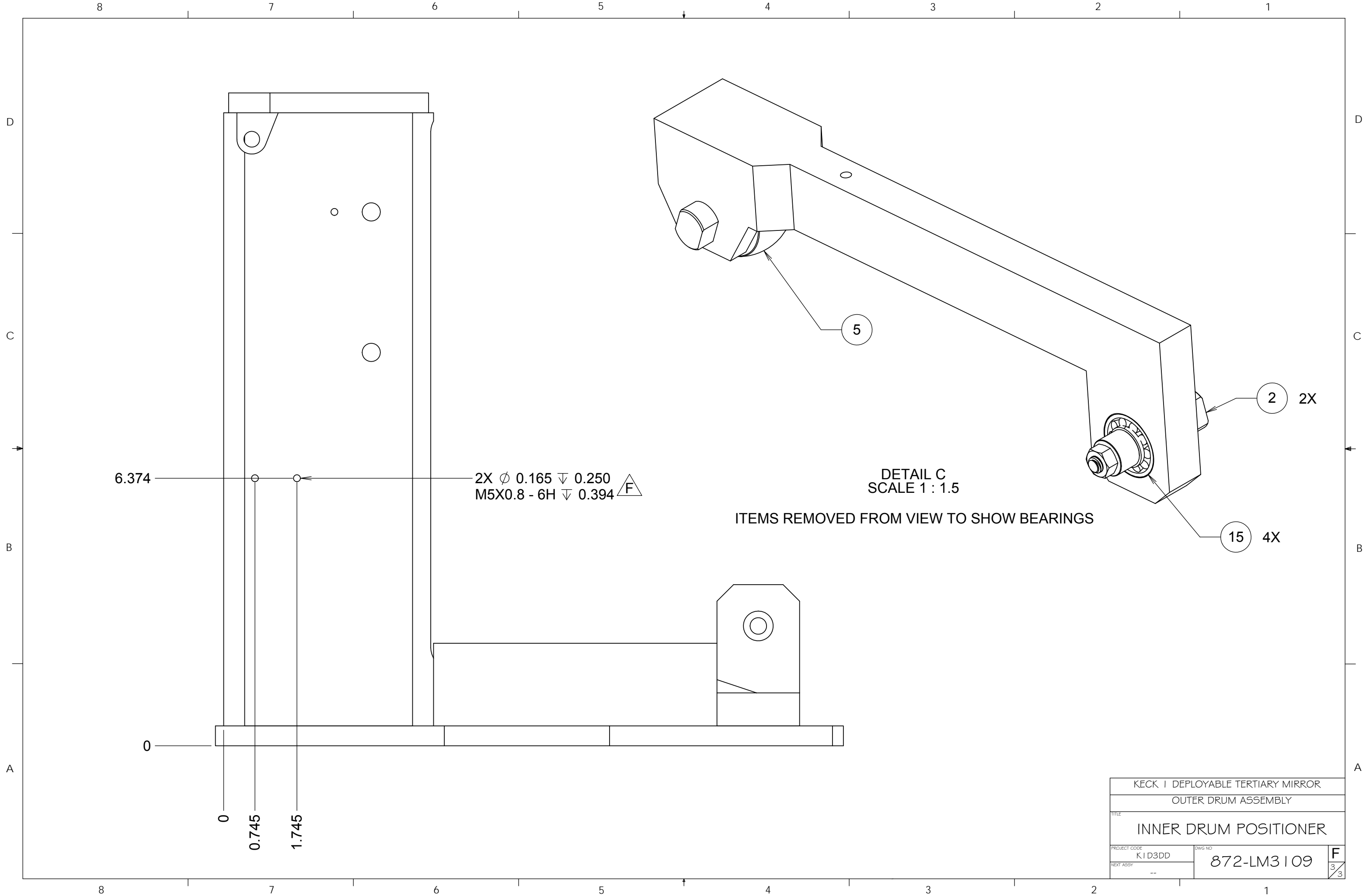

6.374

0

0

0.745

1.745

2X ϕ 0.165 ∇ 0.250 \triangle F
 M5X0.8 - 6H ∇ 0.394

DETAIL C
 SCALE 1:1.5

ITEMS REMOVED FROM VIEW TO SHOW BEARINGS

2 2X

15 4X

KECK I DEPLOYABLE TERTIARY MIRROR	
OUTER DRUM ASSEMBLY	
TITLE INNER DRUM POSITIONER	
PROJECT CODE K1D3DD	DWG NO 872-LM3109
NEXT ASSY --	\triangle F 3/3