

REVISIONS				
DRWN	DATE	CHK'D	REV	DESCRIPTION
CR	5DEC2016		A	PRELIMINARY RELEASE

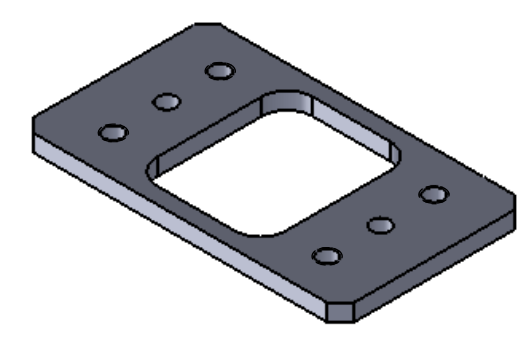
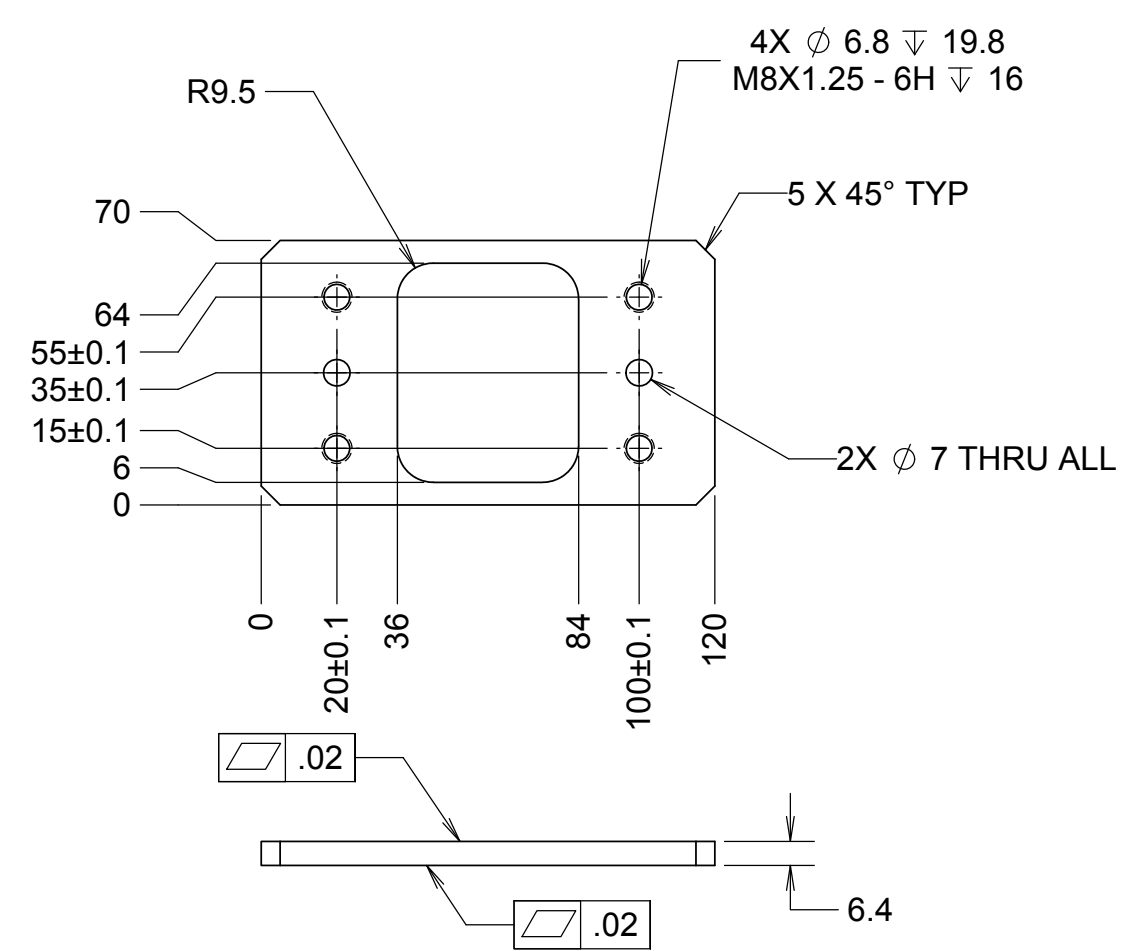

NOTES:
1. None

UNLESS OTHERWISE NOTED DIMENSIONS ARE IN MILLIMETERS & TOLERANCES ARE AS FOLLOWS: X: ±0.25mm X.X: ±0.20 mm X.XX: ±0.01 mm ANGLES: ±0.5° FINISH: 3 MICRONS (µm) BREAK ALL SHARP EDGES & CORNERS .25mm MAX			DRWN C. RATLIFF	KECK 1 DEPLOYABLE TERTIARY MIRROR		
MATERIAL 300 SS	FINISH NONE		CHECKED	Outer Drum		
		DESIGNED	12/5/16	TITLE Defining Point Nut Plate		
		ENGINEER		PROJECT CODE K1D3DD	DWG NO 872-LM3137	REV A
		SW DOCUMENT FILE 872-LM3137	QUANTITY 3	NEXT ASSY KDM3000		