

REVISIONS				
DRWN	DATE	CHK'D	REV	DESCRIPTION
CR	6OCT17		A	PRELIMINARY RELEASE

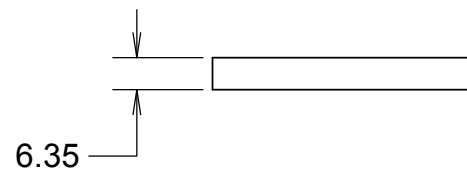
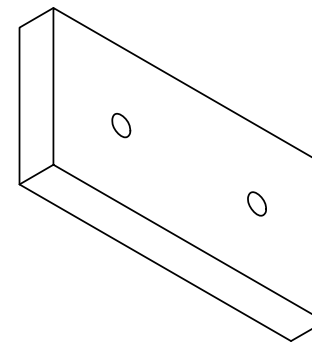
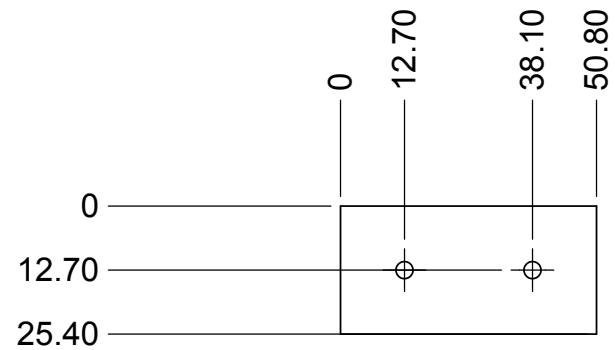

**NOTES**

- 1 CAD MODEL FILENAME, 872-LM 3183 Microswitch Washer Plate
- 2 MATERIAL: STAINLESS STEEL
- 3. BREAK ALL SHARP EDGES

UNLESS OTHERWISE NOTED DIMENSIONS ARE IN MILLIMETERS & TOLERANCES ARE AS FOLLOWS:  
 X.X: ±0.10 mm X.XX: ±0.05 mm  
 ANGLES: ±0.5° FINISH: 3 MICRONS (µm)  
 BREAK ALL SHARP EDGES & CORNERS .25mm MAX



MATERIAL	FINISH
SEE NOTES	

DESIGNED <b>C. RATLIFF</b> ENGINEER	CHECKED <b>DM</b>	QUANTITY <b>1</b>	PROJECT CODE <b>K1D3FD</b>	DWG NO <b>872-LM0000</b>	REV <b>A</b>
DRAWN <b>C. RATLIFF</b> CHECKED <b>DM</b>		TBD	KECK 1 DEPLOYABLE TERTIARY MIRROR <b>OUTER DRUM</b>		
TITLE <b>MICROSWITCH WASHER PLATE</b>		NEXT ASSY <b>872-LM0000</b>	872-LM3183		
SW DOCUMENT FILE 872-LM 3183 Microswitch Washer Plate					

D

C

B

A

D

C

B

A

8

7

6

5

4

3

2

1

8

7

6

5

4

3

2

1