

REVISIONS				
REV	DATE	DRW'N	DESCRIPTION	CHCK'D
A	1/17/2018	CR	INITIAL RELEASE	

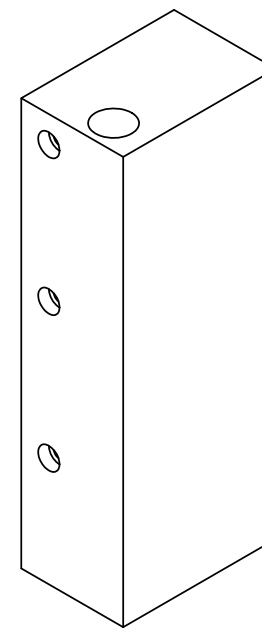
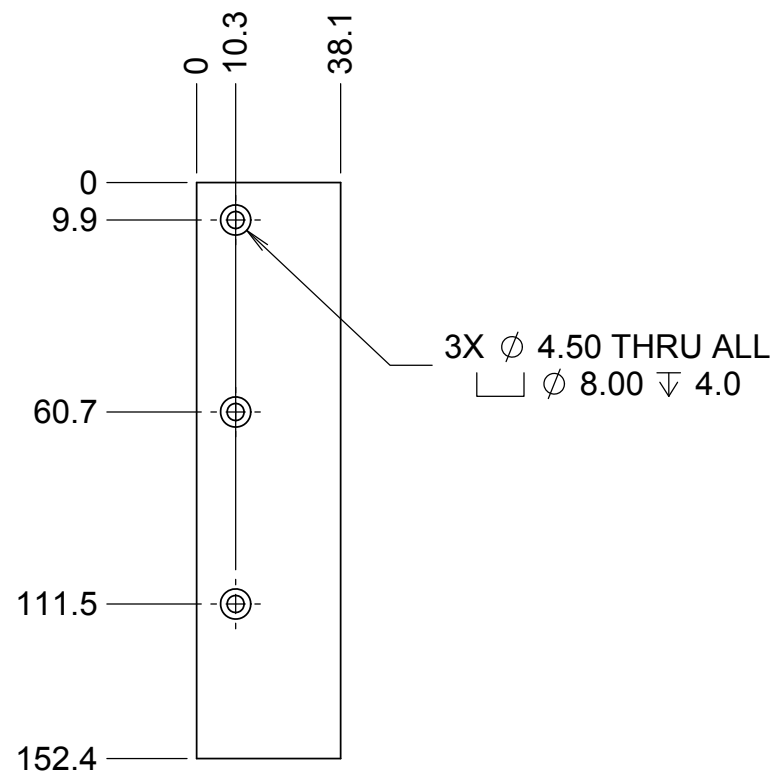
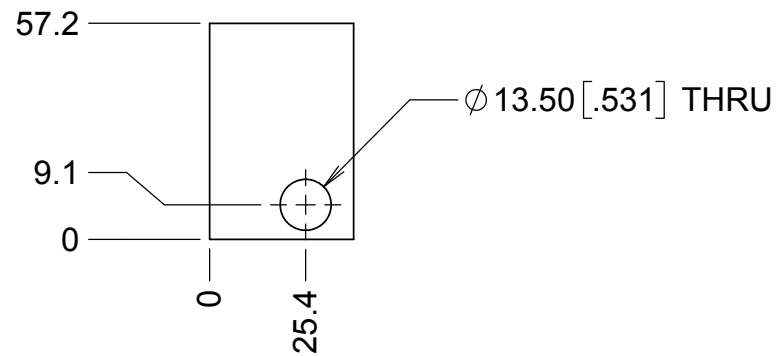

**NOTES**

- CAD MODEL FILENAME, 872-LM3198 Detent Pin Holder
- FINISH: PRIMER & PAINT UCO BEST KNOWN METHOD, BLACK, IF ALUMINUM. IF DELRIN, NO PAINT NEEDED
- MATERIAL: ALUMINUM OR DELRIN

UNLESS OTHERWISE NOTED DIMENSIONS ARE IN MILLIMETERS & TOLERANCES ARE AS FOLLOWS:  
 X.X:  $\pm 0.10$  mm X.XX:  $\pm 0.01$  mm  
 ANGLES:  $\pm 0.5^\circ$  FINISH: 3 MICRONS ( $\mu\text{m}$ )  
 BREAK ALL SHARP EDGES & CORNERS .25mm MAX



MATERIAL	FINISH
SEE NOTE 3	NOTE 2

DRAWN	CR	--	KECK 1 DEPLOYABLE TERTIARY MIRROR	
CHECKED	--	--	OUTER DRUM	
DESIGNED	CR	--	TITLE	
ENGINEER	CR	--	DETENT PIN HOLDER	
SW DOCUMENT FILE	872-LM3198.SLDPRT	QUANTITY	1	PROJECT CODE
				K1D3FD
				DWG NO
				872-LM3198
				REV
				A
				1