

REVISIONS				
REV	DATE	DRW'N	CHCK'D	DESCRIPTION
A	21MAR17	CR	--	INITIAL RELEASE

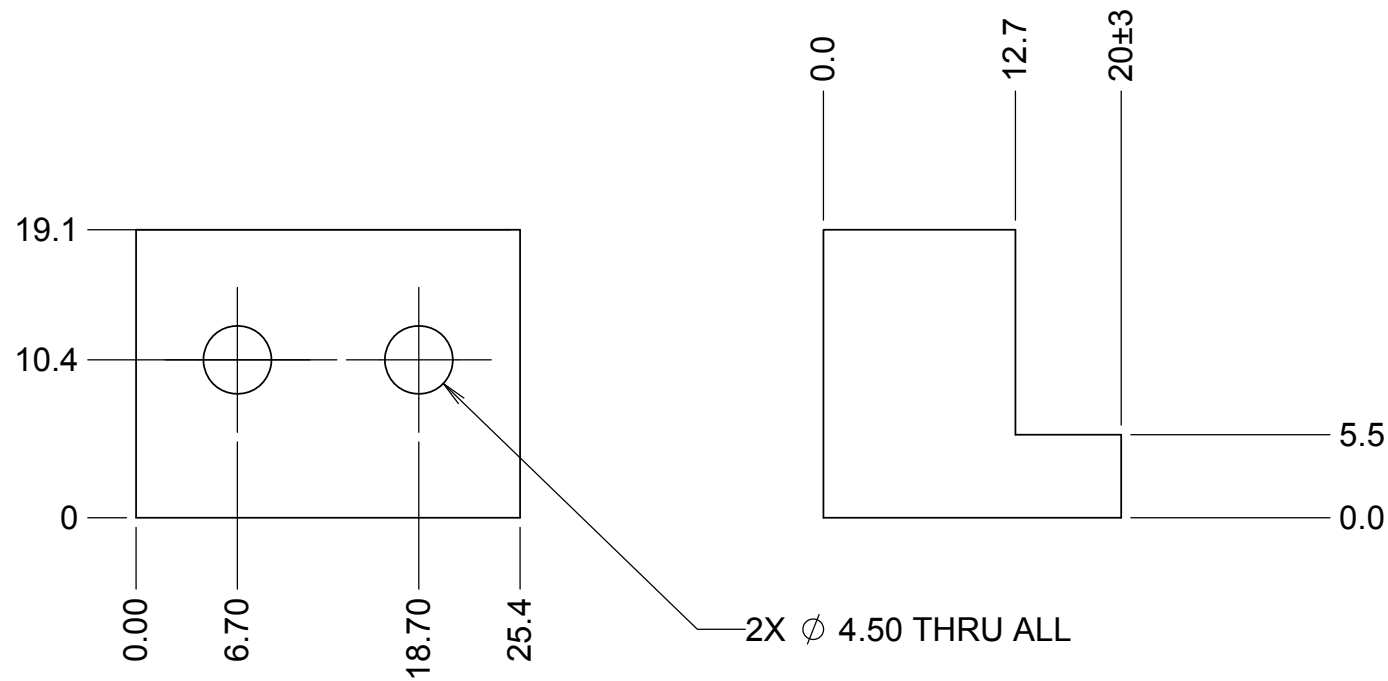
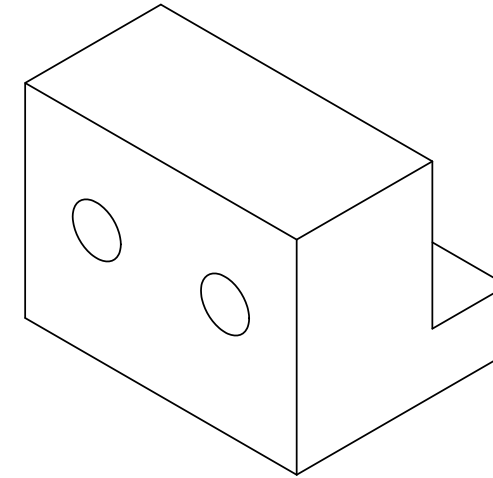

NOTES

- CAD MODEL FILENAME, 872-LM8535 encoder read head drill jig
- MATERIAL: STEEL

UNLESS OTHERWISE NOTED DIMENSIONS ARE IN MILLIMETERS & TOLERANCES ARE AS FOLLOWS:
 X.X: ±0.10 mm X.XX: ±0.04 mm
 ANGLES: ±0.1° FINISH: 3 MICRONS (µm)
 BREAK ALL SHARP EDGES & CORNERS .25mm MAX

MATERIAL	FINISH
NOTE 2	NA



DRAWN	RATLIFF	QUANTITY	1	PROJECT CODE	K1D3FD	DWG NO	872-LM8535	REV	A
CHECKED	DM	QUANTITY	1	TITLE	READ HEAD DRILL JIG				
DESIGNED	CR	QUANTITY	1	PROJECT CODE	K1D3FD	DWG NO	872-LM8535	REV	A
ENGINEER	RATLIFF	QUANTITY	1	PROJECT CODE	K1D3FD	DWG NO	872-LM8535	REV	A
SW DOCUMENT FILE	872-LM8535.SLDPRT	QUANTITY	1	PROJECT CODE	K1D3FD	DWG NO	872-LM8535	REV	A
		QUANTITY	1	PROJECT CODE	K1D3FD	DWG NO	872-LM8535	REV	A